

-2 CRANKCASE COVER

Aluminum Casting

Mill, file, grind, or graunch 1/4" wide channel as indicated to clear 3-7 conrod

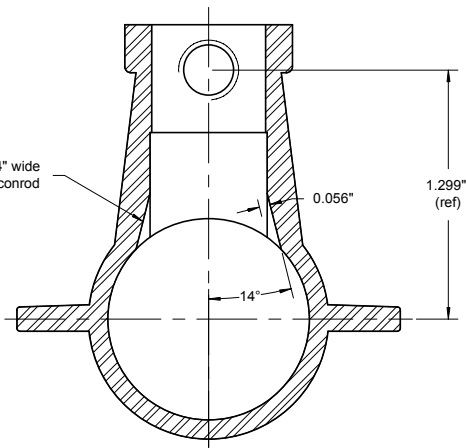

Section A-A

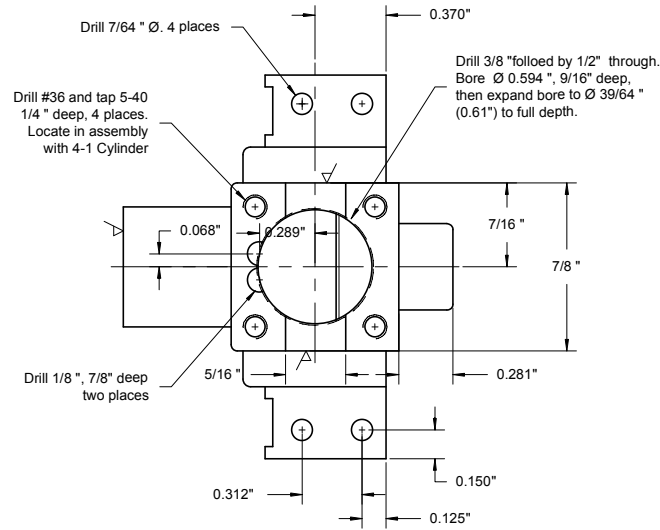

-1 CRANKCASE

Aluminum Casting

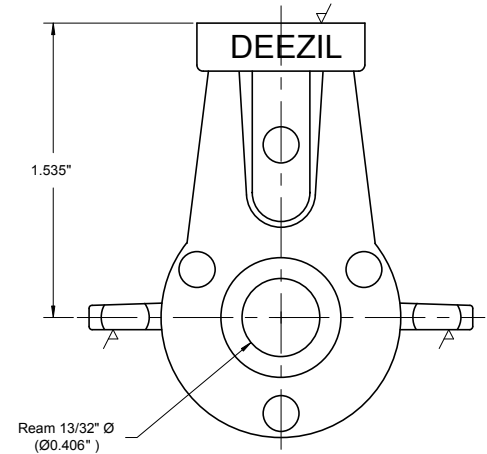
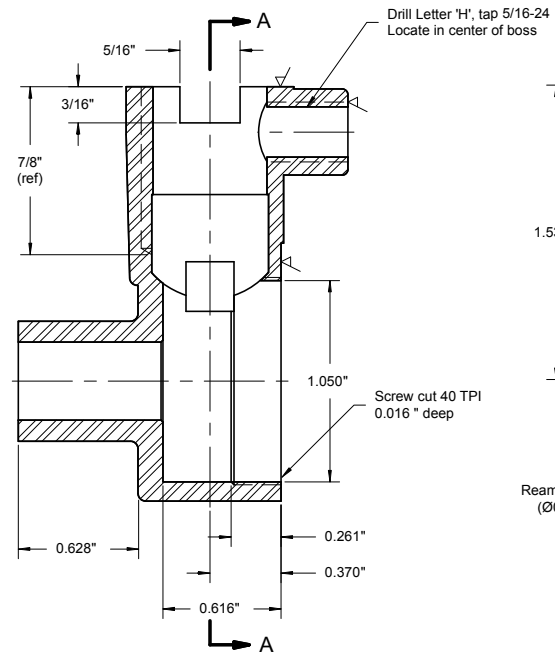

Machine

			MAT'L		DO NOT SCALE DRAWING WORK TO DIMENSIONS ALL DIMENSIONS ARE IN INCHES		NAME
2012-09-07	Add Section A-A with conrod clearance; correct lower cylinder bore diameter dimension.	BMBI	SCALE	FULL SIZE			GOTHAM HOBBY "DEEZIL" ENGINE
2008-11-17	Add missing tap drill size; standardize x-section.	BMBI	DRAWN	RJS Feb 1994			NUMBER
DATE	CHANGE	BY	CAD	BMBI Jan 1999		SHEET 2 - CRANKCASE AND COVER	